

## **The Influence of Work Discipline and Non-Physical Work Environment On Employee Performance (Case Study in One of The Local Government Institutions in The City of Bandung)**

---

**Dita Aulia<sup>1</sup>, Retno Resawati<sup>2</sup>**  
Sekolah Tinggi Ilmu Ekonomi Pasundan, Bandung<sup>1,2</sup>  
Email: [ditaaulia@gmail.com](mailto:ditaaulia@gmail.com)<sup>1</sup>, [retno@stiepas.ac.id](mailto:retno@stiepas.ac.id)<sup>2</sup>

### **ABSTRACT**

*The researcher conducted a study to understand the impact of work discipline and non-physical work environment on employee performance in a local government agency in Bandung. Additionally, this research aims to analyze the most dominant factors influencing employee performance between work discipline and the non-physical work environment in this particular local government agency being studied. The researchers interviewed 65 employees using questionnaires.*

*The research using path analysis found that the variables of work discipline and non-physical work environment in one of the local government agencies in the city of Bandung are valid. The conclusions and considerations regarding the research results emphasize the importance of paying attention to work discipline and non-physical work environment to enhance employee performance. The research findings indicate that Work Discipline (X1) significantly influences Employee Performance (Y). Furthermore, the Non-Physical Work Environment (X2) also significantly influences Employee Performance (Y).*

*To improve work discipline in one of the local government agencies in Bandung, we recommend that supervisors allocate time to supervise the implementation of company tasks and impose appropriate sanctions on employees who violate discipline. Leaders must pay attention to and be aware of any violations committed by anyone without discrimination among the employees. The company should also provide recognition to employees who perform well to enhance their performance. To improve the non-physical work environment, the researcher recommends organizing events or activities that can strengthen the relationship between employees and superiors, fostering mutual assistance and care among them. The local government agency should also maintain leaders who provide technical assistance to subordinates when they face difficulties, as it will significantly assist other employees.*

*Keywords: Work Discipline, Non-Physical Work Environment, Employee Performance.*

## INTRODUCTION

Human resources are the main driving force behind an organization's activities, and the quality of its human resources dramatically determines its success. Therefore, employees or human resources within an organization are crucial factors in achieving organizational success (Coun et al., 2022; Suryadana & Sidharta, 2019). The ability of employees to carry out their tasks becomes an indicator of achieving organizational goals (Machmud & Sidharta, 2021; Manik & Sidharta, 2017). All types of organizations, including government organizations, can succeed by fulfilling their goals. (Christensen et al., 2020; Hadian, 2018). The best service an organization provides also relies on each employee's role (Ansell et al., 2021; Rasool et al., 2019). Employees must be able to work optimally, which can be observed or measured through their performance.

Improvement in employee performance has the potential to bring development to the institution or organization in order to sustain unstable competition. Factors influencing employee performance include aspects of the workforce and the company or organizational environment (George et al., 2019).

The implementation of management in government agencies still needs to consider comparing the competence and qualifications of prospective employees in the recruitment, appointment, placement, and promotion

processes. This situation aligns with the principles of good governance and efforts to reform the bureaucracy. Therefore, it is necessary to establish employees as profession that has a responsibility to manage and improve themselves and be accountable for their performance, as well as to apply merit principles in effective management practices (Christensen et al., 2020). Employees in one of the local government agencies in the city of Bandung have suboptimal performance or need to meet the organization's expectations. The expected employee performance should align with the goals to be achieved by the organization, which depends on the employees within the organization. Employees in one of the local government agencies in the city of Bandung should have a strong desire to work and achieve success, both individually and in the organization, to achieve optimal employee performance. This desire arises in conjunction with the needs of the employees. Conversely, if the employee's performance is high, it will result in effective and efficient performance.

Opinions (Aguinis, 2019) indicate that the performance assessment report of employees in one of the local government agencies in Bandung categorizes their performance as good but suggests that it needs improvement and the expectations of the local government agency in Bandung. Performance is the quality and quantity

of work an employee achieves in carrying out their duties according to their responsibilities.

Performance refers to the individual or group achievements in quantity and quality of work within an organization or company (Foster & Sidharta, 2019). The performance outcomes are not limited to functional or structural personnel but encompass all organization members. The factors influencing performance include discipline (Hersona & Sidharta, 2017), the working relationship between subordinates and superiors (Hadian et al., 2022; Machmud, 2018), working facilities (Dziuba et al., 2020), leadership patterns (Hai et al., 2022; Hirst et al., 2009), and the working environment (Machmud & Sidharta, 2021).

The described phenomenon above occurs due to deviations in performance factors. The declining performance achievements from 2020 to 2021 indicate the need for improvement. Performance factors include a better understanding of quality, quantity, task execution, responsibility, discipline, and the working environment.

According to opinions (Cesário & Chambel, 2017; Hamadamin & Atan, 2019), Generally, one can interpret performance as the individual's success in performing their tasks. Good performance refers to the execution of tasks by established procedures or standards.

Based on the employee attendance report in one of the local government agencies in Bandung, we can see that employee absenteeism fluctuates every month. Considering the significant percentage of absenteeism, the researcher suspects it is due to a lack of self-awareness regarding work discipline. Employees should improve their quality and level of productivity. This condition aligns with the opinion (Hersona & Sidharta, 2017) that high work discipline leads to good employee performance. Conversely, low work discipline results in a decline in employee performance.

Discipline is a manifestation of employees' respect for the rules and regulations in the organization. Employees who ignore or frequently violate these rules and regulations require a higher level of compliance (Mustofa et al., 2021). Conversely, if employees are obedient and adhere to company regulations, it reflects good compliance. Specifically, and generally, compliance refers to actions taken to correct incorrect behavior and attitudes exhibited by employees. In other words, work discipline is the state or willingness of employees to comply with the applicable rules in the organization, which ultimately affects the achievement of the organization's goals.

In addition to discipline, the researcher suspects that the non-physical work environment in one of the local government agencies in Bandung is another factor causing low employee

performance. This condition includes relationships with colleagues and between employees and agency leaders, which must be well-established, resulting in poor communication and collaboration (Steingold, 2021; Thompson et al., 2020).

The work environment encompasses all physical and non-physical aspects that directly influence employees in carrying out their tasks and work (Machmud & Sidharta, 2021). Therefore, organizations are expected to maintain a good and conducive work environment, including fostering relationships among employees, interacting with the community, creating a positive work atmosphere, ensuring employee welfare, and considering other non-physical work environment factors that affect employee performance in carrying out tasks and work. A good work environment can support employee performance and enhance motivation and productivity.

A conducive non-physical work environment provides comfort and enables employees to work optimally. If employees enjoy the non-physical work environment in which they work, they will feel satisfied in their workplace, engage in their activities, and utilize their work time effectively. Conversely, an adequate non-physical work environment can improve employee performance. Employee performance is essential for government agencies to provide the best service to the community.

The preliminary survey results indicate that the non-physical work environment needs to be considered better and more conducive. The aspects of the non-physical work environment have the potential to influence employee performance in carrying out their tasks and work. A good work environment can support employee performance and enhance motivation and enthusiasm.

According to Machmud & Sidharta (2021), the work environment or working conditions, especially its non-physical aspects, is one of the elements that companies should give attention to. It has an impact on work productivity, work motivation (Locke & Schattke, 2019), job satisfaction (Liu et al., 2021), job performance (Jiang et al., 2012), and employee performance (Dziuba et al., 2020).

Based on the above problem background, the research problem formulation is the extent of the influence of work discipline and non-physical work environment on employee performance. This research aims to determine the magnitude of the influence of work discipline and non-physical work environment on employee performance.

## METHOD

In this study, we apply descriptive and verificative methods. We use the descriptive method to provide an overview and explanation of the conditions in the company based on facts and characteristics of the population, relying on the

collected data. We systematically analyze the data to formulate conclusions. On the other hand, we use the verificative method to determine the interval level of assessment criteria for the two variables under investigation. We then perform the average calculation for each respondent's response.

To test the research hypothesis, the sample size in this study consists of 65 respondents from the total number of employees in one of the local government agencies in Bandung. This study's independent variables (X) are work discipline and non-physical work environment. Work discipline is implementing management to strengthen organizational guidelines (Hersona & Sidharta, 2017). The dimensions of work discipline are preventive, progressive, and corrective.

Meanwhile, the non-physical work environment refers to all conditions related to relationships among coworkers or relationships between superiors and subordinates (Dziuba et al., 2020). The dimensions of the non-physical work environment are relationships among coworkers and the relationship between superiors and subordinates.

The dependent variable (Y) in this study is employee performance. Employee performance is the qualitative and quantitative output an employee achieves in carrying out their tasks according to their responsibilities (Hadian, 2018; Taufik et al., 2022). The dimensions of employee performance are work quality, work time, and cost

or budget. To test the research hypotheses, the researcher utilizes path analysis to determine the direct and indirect effects of the research variables.

## RESULT AND DISCUSSION

In this study, there are characteristics of respondents who become the object of research. As in the table below:

**Table 1. Characteristics of Respondents**

N O	Characterist ics of Respondent s	Amount Responde nts	Percenta ge
1.	Usia:		
	a. 25 to 35	29	45%
	b. 36 to 45	16	25%
	c. 46 to 55	17	26%
	d. > 55	3	5%
2.	Last Education:		
	a. Senior Hight School	2	3%
	b. D3	6	9%
	c. S1	48	74%
	d. S2	9	14%

From the results of the respondents' answers, as many as 65 people showed the results of the validity and reliability tests in the table below:

**Table 2. Validity Test Results and Reliability**

Tests					
X1 (Work Discipline)		X2 (Non-Physical Work Environment)		Y (Employee Performance)	
Ite ms	Correl ation	Ite ms	Correl ation	Ite ms	Correl ation
1	0.485	1	0.479	1	0.467
2	0.652	2	0.614	2	0.610
3	0.655	3	0.671	3	0.687
4	0.561	4	0.444	4	0.492
5	0.481	5	0.357	5	0.414
6	0.482	6	0.498	6	0.424
7	0.540	7	0.592	7	0.420
8	0.667	8	0.805	8	0.659
9	0.459	9	0.422	9	0.514
10	0.696	10	0.768	10	0.551
11	0.728	11	0.572	11	0.545
12	0.644	12	0.574	12	0.538
13	0.793	13	0.775	13	0.402
14	0.624	14	0.615	14	0.461
15	0.616			15	0.523
Cronbach Alpha					
X1	0,875				
X2	0,854				
Y	0,799				

Based on Table 2, it is shown that the work discipline variable consists of 15 statement items, the non-physical work environment variable consists of 14 statement items and the employee performance variable consists of 15 statement items with correlation values above 0.300 (valid). The reliability test obtained a Cronbach's alpha value above 0.700 (valid).

Based on the calculation results, the work discipline variable (X1) obtained a path coefficient of 0.339, and the non-physical work environment variable had a path coefficient of 0.409. As shown in Figure 1 below:

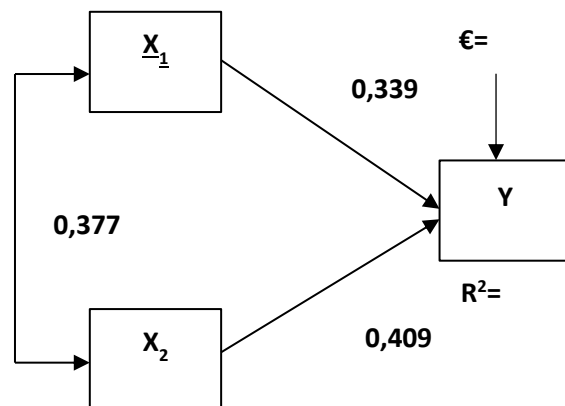

**Figure 1. Path Analysis Results**

Based on the calculations of direct and indirect effects, it shows that the Work Discipline variable (X1) has a direct influence with a percentage of 11.49%, the Non-Physical Work Environment variable (X2) has an indirect influence with a percentage of 5.23% and the actual influence with a percentage of 16.72%.

The Non-Physical Work Environment variable (X2) has a direct influence of 26.73%, the Work Discipline variable (X1) has an indirect influence of 5.23%, and the actual influence with a percentage of 21.96%. This results in an overall influence of 38.67%.

Based on the calculations conducted above, work discipline influences employee performance. A good level of discipline among employees indicates that the company can maintain and preserve employee loyalty and quality. Additionally, by knowing the employee work discipline level, we can assess their performance. There is a correlation between work discipline and employee performance.

By consistently implementing work discipline, we can address poor performance issues and strengthen the influence of employee work behavior within the group or organization. By maintaining good discipline and avoiding work procrastination, we can prevent performance issues from worsening and enable us to address emerging problems effectively and efficiently (Thompson et al., 2020).

Employees who apply discipline consistently will become familiar with good work standards and instructions. This situation can motivate employees to achieve goals, but it does not guarantee that applying work discipline to employees will result in high performance (Taufik et al., 2022). Therefore, organizations need to prioritize the intensity and quality of these efforts,

focusing on organizational goals. Discipline is a fundamental principle for employees to carry out their work in the company, fostering employee accountability for their work and its outcomes.

If a company improves work discipline among employees, it will generate more significant benefits. Enhancing work discipline enables employees to complete tasks more quickly, reduce damages, minimize absenteeism, and lower employee turnover (Caissar et al., 2022). Every organization aims to create quality human resources as it directly impacts employee performance. Hence, companies must effectively address challenges in developing work discipline to motivate employees to attain the organization's desired goals.

A comfortable work environment can foster a positive emotional attitude among employees, where they enjoy and love their work. Employees' work morale, discipline, and performance reflect this attitude. Employees who enjoy their work environment prioritize their job over the rewards provided by the company. Although these rewards remain essential, the satisfaction obtained from work outcomes and the ability to meet daily needs can enhance employees' trust in the company. Consequently, these employees will consistently deliver good results for the company (Machmud & Sidharta, 2021). The work environment is a crucial factor related to employee enthusiasm. A good work environment

can inspire high motivation, ultimately improving employee performance.

The non-physical work environment encompasses work relationships among employees. This condition includes fostering good relationships with superiors and colleagues. It is essential to create harmonious relationships among coworkers and avoid conflicts in the workplace. Research on the non-physical work environment aims to develop positive attitudes among employees that support their performance. Several studies support the notion that the non-physical work environment positively and significantly impacts employee performance (Pangestuti, 2020; Jayaningrum et al., 2020).

Based on the research findings, work discipline, and the non-physical work environment collectively influence employee performance. This finding aligns with theories stating that factors affecting employee performance can originate from individual and organizational environmental factors. Companies can enhance employee performance by ensuring awareness and compliance with rules within the organization. Additionally, creating a favorable organizational work environment also contributes to employee performance, where a pleasant non-physical work environment can facilitate employees in carrying out their tasks comfortably. Employees will achieve good performance by considering work discipline and the non-physical work environment, enabling the company to accomplish its goals.

## CONCLUSION

The results of the one-way analysis processing indicate that work discipline and non-physical work environment simultaneously influence employee performance in one of the departments in Bandung City, with a contribution of 38.67%, indicating a weak correlation between work discipline and non-physical work environment, while the remaining 61.23% is determined by other variables not included in this study, such as the physical work environment, motivation, and others. Therefore, work discipline and the non-physical work environment variables explain employee performance. Furthermore, discipline and the non-physical work environment provide a positive coefficient direction.

Based on the above conclusion, the researcher provides suggestions to one of the local government agencies in Bandung City. To improve work discipline, supervisors need to monitor the progress of company tasks and impose appropriate sanctions for employee disciplinary violations. Leaders need to be aware of the violations committed without differentiating between employees. The company should also provide recognition to high-performing employees to enhance employee performance.

To enhance the non-physical work environment, we recommend that the company organizes activities or events that strengthen the relationships between employees and superiors,



fostering a sense of care and mutual assistance among colleagues. Leaders should also provide technical support to subordinates facing difficulties, as this can also aid other employees. The institution should also create new agendas to improve the non-physical work environment through in-office and out-of-office events such as gatherings, outbound activities, savings groups, or other activities outside working hours. This result aims to create personal closeness among employees and enhance job satisfaction.

In addition to improving work discipline and enhancing the non-physical work environment, we advise the company to build a good relationship between employees and superiors to achieve good performance. The company should also provide opportunities for employees to develop knowledge and skills relevant to their tasks through job-specific training. Furthermore, the company needs to create a supportive work environment, considering that employees spend most of their time in the office. This result will help boost work enthusiasm and employee performance.

## REFERENCES

- Aguinis, H. (2019). *Performance management* (4th ed.). Chicago Business Press.
- Ansell, C., Sørensen, E., & Torfing, J. (2021). The COVID-19 pandemic as a game changer for public administration and leadership? The need for robust governance responses to turbulent problems. *Public Management Review*, 23(7), 949–960. <https://doi.org/10.1080/14719037.2020.1820272>
- Caissar, C., Hardiyana, A., Nurhadian, A. F., & Kadir, K. (2022). Pengaruh Motivasi Kerja Dan Disiplin Kerja Terhadap Kinerja Karyawan. *Acman: Accounting and Management Journal*, 2(1), 11–19. <https://doi.org/10.55208/aj.v2i1.27>
- Cesário, F., & Chambel, M. J. (2017). Linking Organizational Commitment and Work Engagement to Employee Performance. *Knowledge and Process Management*, 24(2), 152–158. <https://doi.org/10.1002/kpm.1542>
- Christensen, J., Aarøe, L., Baekgaard, M., Herd, P., & Moynihan, D. P. (2020). Human Capital and Administrative Burden: The Role of Cognitive Resources in Citizen-State Interactions. *Public Administration Review*, 80(1), 127–136. <https://doi.org/10.1111/puar.13134>
- Dziuba, S. T., Ingaldi, M., & Zhuravskaya, M. (2020). Employees' Job Satisfaction and their Work Performance as Elements Influencing Work Safety. *System Safety: Human - Technical Facility - Environment*, 2(1), 18–25. <https://doi.org/10.2478/czoto-2020-0003>
- Foster, B., & Sidharta, I. (2019). *Dasar - Dasar Manajemen*. Diandra Kreatif.

- George, B., Walker, R. M., & Monster, J. (2019). Does Strategic Planning Improve Organizational Performance? A Meta-Analysis. *Public Administration Review*, 79(6), 810–819. <https://doi.org/10.1111/puar.13104>
- Hadian, D. (2018). Pengaruh Kepemimpinan Transformasional terhadap Motivasi Instrinsik dan Komitmen Kerja serta dampaknya terhadap Kinerja Pegawai. *Kontigensi : Jurnal Ilmiah Manajemen*, 6(1), 1–8. <https://doi.org/10.56457/jimk.v6i1.48>
- Hadian, D., Juhana, D., Sukmalana, S., Hardiyana, A., Yusup, M., Sidharta, I., Nurhadian, A. F., & Rinawati, N. (2022). Authentic Leadership on Employee Coping and Its Impact on Psychological Vulnerable: Survey on Public Organization in Bandung, Indonesia. *Academic Journal of Interdisciplinary Studies*, 11(5). <https://doi.org/10.36941/ajis-2022-0131>
- Hai, M., Latif, S., Bilal, A. R., & Ahmad, B. (2022). Respect: give it to get it! Does leadership complimented with respect can foster creativity? *International Journal of Emerging Markets*, 17(2), 621–644. <https://doi.org/10.1108/IJOEM-11-2019-0931>
- Hamadamin, H. H., & Atan, T. (2019). The Impact of Strategic Human Resource Management Practices on Competitive Advantage Sustainability: The Mediation of Human Capital Development and Employee Commitment. *Sustainability*, 11(20), 5782. <https://doi.org/10.3390/su11205782>
- Hersona, S., & Sidharta, I. (2017). INFLUENCE OF LEADERSHIP FUNCTION, MOTIVATION AND WORK DISCIPLINE ON EMPLOYEES' PERFORMANCE. *Jurnal Aplikasi Manajemen*, 15(3), 528–537. <https://doi.org/10.21776/ub.jam.2017.015.03.18>
- Hirst, G., van Dick, R., & van Knippenberg, D. (2009). A social identity perspective on leadership and employee creativity. *Journal of Organizational Behavior*, 30(7), 963–982. <https://doi.org/10.1002/JOB.600>
- J. H. Coun, M., Peters, P., Blomme, R. J., & Schaveling, J. (2022). 'To empower or not to empower, that's the question'. Using an empowerment process approach to explain employees' workplace proactivity. *International Journal of Human Resource Management*, 33(14), 2829–2855. <https://doi.org/10.1080/09585192.2021.1879204>
- Jayaningrum, S. K., Kirana, K. C., & Wiyono, G. (2020). ANALISIS KOMPETENSI DAN KOMPENSASI TERHADAP KINERJA KARYAWAN BERBASIS LINGKUNGAN KERJA NON FISIK. *JBE (Jurnal Bingkai Ekonomi)*, 5(2), 16–26. <https://doi.org/10.54066/jbe.v5i2.83>
- Jiang, J., Wang, S., & Zhao, S. (2012). Does HRM facilitate employee creativity and

- organizational innovation? A study of Chinese firms. *International Journal of Human Resource Management*, 23(19), 4025–4047.  
<https://doi.org/10.1080/09585192.2012.690567>
- Liu, Y., Vriend, T., & Janssen, O. (2021). To Be (Creative), or not to Be (Creative)? A Sensemaking Perspective to Creative Role Expectations. *Journal of Business and Psychology*, 36(1), 139–153.  
<https://doi.org/10.1007/S10869-019-09669-0>
- Locke, E. A., & Schattke, K. (2019). Intrinsic and extrinsic motivation: Time for expansion and clarification. *Motivation Science*, 5(4), 277–290. <https://doi.org/10.1037/mot0000116>
- Machmud, S. (2018). The Influence of Self-Efficacy on Satisfaction and Work-Related Performance. *INTERNATIONAL JOURNAL OF MANAGEMENT SCIENCE AND BUSINESS ADMINISTRATION*, 4(4), 43–47.  
<https://doi.org/10.18775/ijmsba.1849-5664-5419.2014.44.1005>
- Machmud, S., & Sidharta, I. (2021). Working Condition On Employee Quality Of Life Outcome: Perspectives From Pandemic COVID-19. *Journal of Applied Business Research (JABR)*, 37(6), 217–224.  
<https://doi.org/10.19030/jabr.v37i6.10396>
- Manik, E., & Sidharta, I. (2017). The Impact of Motivation, Ability, Role Perception on Employee Performance and Situational Factor as Moderating Variable of Public Agency in Bandung, Indonesia. *INTERNATIONAL JOURNAL OF MANAGEMENT SCIENCE AND BUSINESS ADMINISTRATION*, 3(4), 65–73.  
<https://doi.org/10.18775/ijmsba.1849-5664-5419.2014.34.1008>
- Mumford, M. D., Fichtel, M., England, S., & Newbold, T. R. (2023). Leader Thinking, Follower Thinking: Leader Impacts on Follower Creative Performance. *Annual Review of Organizational Psychology and Organizational Behavior*, 10, 413–440.  
<https://doi.org/10.1146/ANNUREV-ORGPSYCH-120920-045553>
- Mustofa, Indartono, S., & Sukidjo. (2021). The Effect of Communication Style on Teaching Motivation, Work Ethics, Emotional Intelligence, Reading Proficiency and Knowledge Sharing. *Integration of Education*, 25(4), 562–576.  
<https://doi.org/10.15507/1991-9468.105.025.202104.562-576>
- Pangestuti, N. A. (2020). Pengaruh Lingkungan Kerja Fisik dan Non Fisik Serta Stres Kerja Terhadap Kinerja Karyawan Pabrik Suka Rasa Bakery. *Jurnal Manajemen*, 10(2), 79.  
<https://doi.org/10.26460/jm.v10i2.1407>
- Rasool, S. F., Samma, M., Wang, M., Yan, Z., & Zhang, Y. (2019). How Human Resource Management Practices Translate Into Sustainable Organizational Performance:
-

The Mediating Role Of Product, Process And Knowledge Innovation. *Psychology Research and Behavior Management*, Volume 12, 1009–1025.

<https://doi.org/10.2147/PRBM.S204662>

(<https://creativecommons.org/licenses/by-nc-sa/4.0/>).

Steingold, F. S. (2021). *The Employer's Legal Handbook: How to Manage Your Employees & Workplace*. Nolo.

Suryadana, M. L., & Sidharta, I. (2019). *MANAJEMEN SUMBER DAYA MANUSIA INDUSTRI HOSPITALITY*. Diandra Kreatif.

Taufik, M. S., Machmud, S., Zulfikar, V. A., & Coenraad, D. P. (2022). PENGARUH MOTIVASI DAN DISIPLIN KERJA TERHADAP KINERJA KARYAWAN (STUDI PADA SALAH SATU PERUSAHAAN VENDOR ALAT TELEKOMUNIASI DI KOTA BANDUNG). *JURNAL COMPUTECH & BISNIS*, 16(1), 20.  
<https://doi.org/10.56447/jcb.v16i1.255>

Thompson, P., McDonald, P., & O'Connor, P. (2020). Employee dissent on social media and organizational discipline. *Human Relations*, 73(5), 631–652.  
<https://doi.org/10.1177/0018726719846262>



© 2023 by the authors. Submitted for possible open access publication under the terms and conditions of the Creative Commons Attribution (CC Attribution-NonCommercial-ShareAlike 4.0) license